

RoHS REACH CFSI

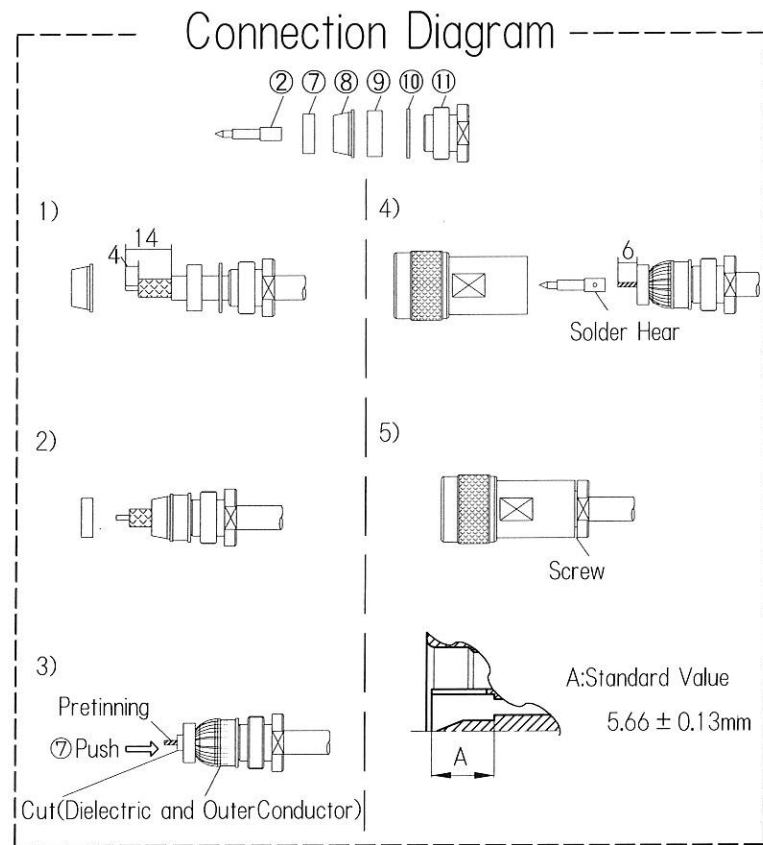
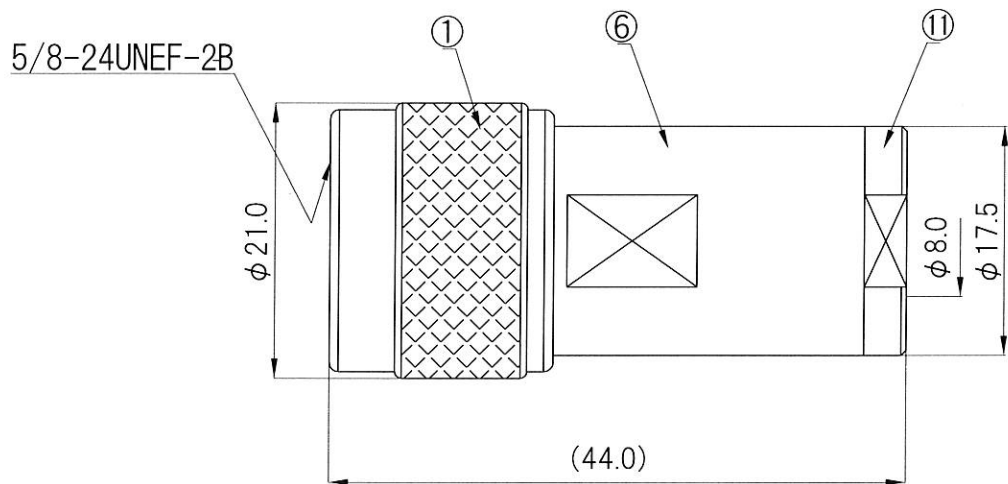

## Electrical

Impedance : 50 Ω  
 Working Frequency Range : DC to 6GHz  
 V.S.W.R. : 1.1+0.025f or Lower (f : Frequency at ~6GHz)  
 Insertion Loss : 0.1√f dB or Lower (f : Frequency at ~6GHz)  
 Proof voltage : AC1,000V RMS  
 Insulation resistance : 5,000MΩ or More  
 Contact resistance : 2.0mΩ or Lower  
 Standard : JIS-C-5411, MIL-C-39012

①	End Nut	Brass	Nickel
⑩	Washer	Brass	Nickel
⑨	Gasket B	Nitrile	Red
⑧	Clamp	Brass	Nickel
⑦	Bushing	Brass	Nickel
⑥	Body	Brass	Nickel
⑤	Dielectric	PTFE	None
④	Ring	P.Bronze	Nickel
③	Gasket A	Nitrile	Red
②	Contact	Brass	Gold
①	Coupling Nut	Brass	Nickel
No.	Description	Material	Finish

Approved エレパーツ '17.09.01 深田A	Checked エレパーツ '17.09.01 木内	Drawn エレパーツ '17.09.01 大島	Unit mm	Scale A4	Title: N ST.CLAMP MALE CONNECTOR	Sheet 1/1
DWG.No. 日本エレパーツ株式会社 NIHON ELEPARTS CO.,LTD.					N-PS-5DSFA	